

DOUBLE SWIVEL LIFTING POINT

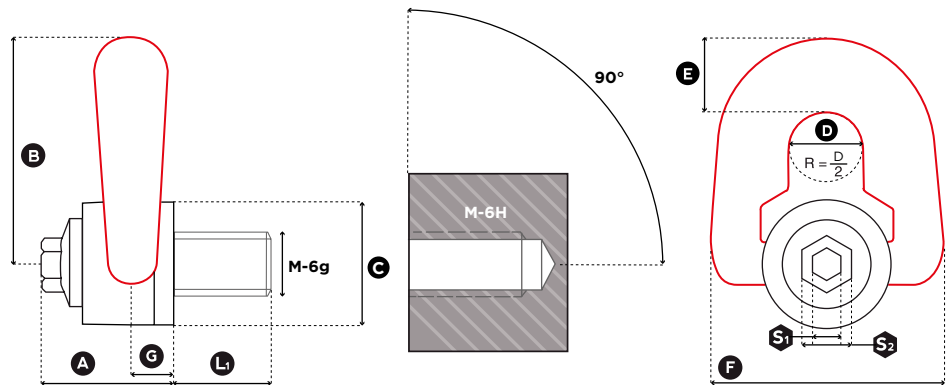

1 in = 25.4 mm

Reference	Diameter	SF 5:1 WLL (t)	Standard L ₁ (mm)	Torque (Nm)	S ₁ (mm)	S ₂ (mm)	A (mm)	B (mm)	C (mm)	D (mm)	E (mm)	F (mm)	G (mm)	Weight (kg)
DSP M 8	M 8 (x1,25)	0,40	15	6	8	16	33	56	30	19	19	58	9,5	0,3
DSP M 10	M 10 (x1,50)	0,70	18	10	8	16	33	56	30	19	19	58	9,5	0,3
DSP M 12	M 12 (x1,75)	1,05	21	15	8	16	33	56	30	19	19	58	9,5	0,3
DSP M 14	M 14 (x2)	1,40	23	30	8	20	45	81	45	25	27	79	13	0,9
DSP M 16	M 16 (x2)	2,00	27	50	8	20	45	81	45	25	27	79	13	0,9
DSP M 18	M 18 (x2,5)	2,30	27	70	8	20	45	81	45	25	27	79	13	1,0
DSP M 20	M 20 (x2,5)	2,50	30	100	8	20	45	81	45	25	27	79	13	1,0

DOUBLE SWIVEL LIFTING POINT

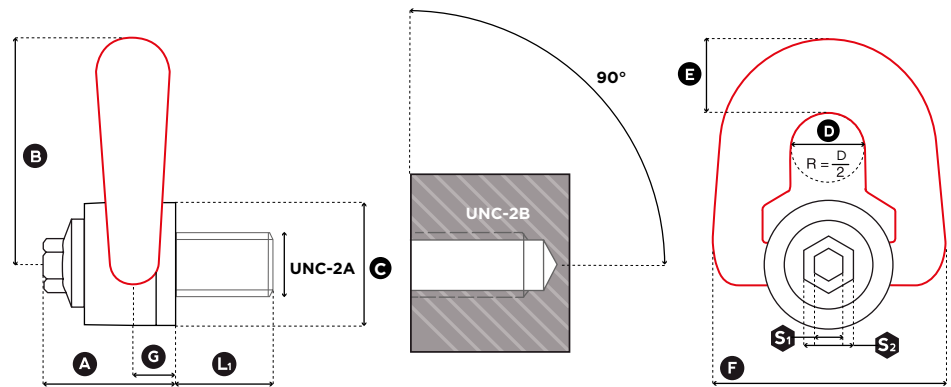

1 in = 25.4 mm

Reference	Diameter	SF 5:1 WLL (lbs)	Standard L ₁ (mm)	Torque (ft-lb)	S ₁ (mm)	S ₂ (mm)	A (mm)	B (mm)	C (mm)	D (mm)	E (mm)	F (mm)	G (mm)	Weight (kg)
DSP U 516	UNC 5/16"-18	1,000	15	7	8	16	33	56	30	19	19	58	9,5	0,3
DSP U 038	UNC 3/8"-16	1,300	17	8	8	16	33	56	30	19	19	58	9,5	0,3
DSP U 050	UNC 1/2"-13	2,400	21	12	8	16	33	56	30	19	19	58	9,5	0,3
DSP U 058	UNC 5/8"-11	3,900	27	40	8	16	45	81	45	25	27	79	13,0	1,0
DSP U 075	UNC 3/4"-10	5,250	30	80	8	16	45	81	45	25	27	79	13,0	1,0